

GARSITE

Above Ground Storage Tanks & Pumping Systems

Complete bulk storage and self-service system for Aviation and Motor fuels.
All systems meet local, state, industry regulations and EPA guidelines.

FUELING MADE SIMPLE



Avgas Storage & Pumping

Tanks: 500 to 30,000 Gallons

Pumping Systems: 22 GPM in-to-plane to 400 GPM bulk loading

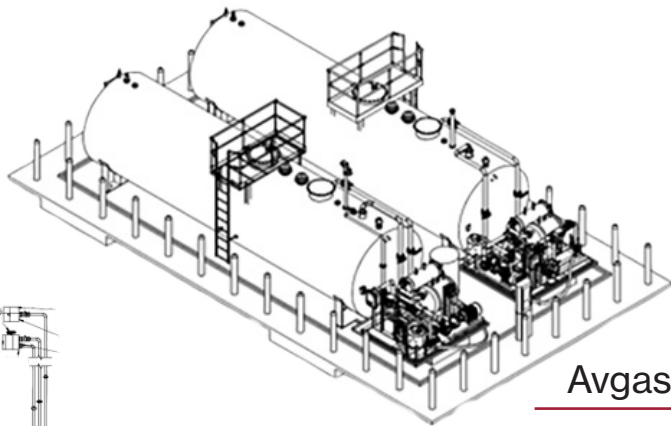

Avgas & Jet-A Bulk System

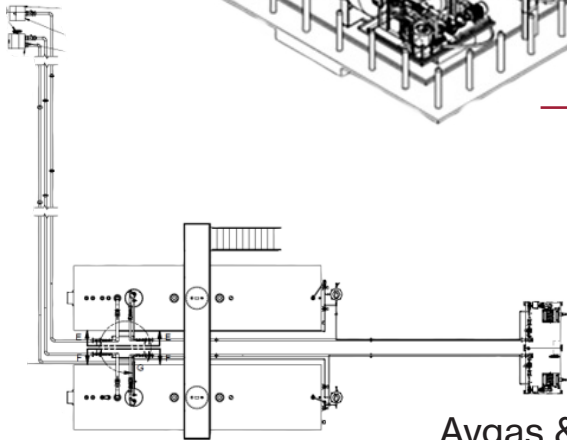

Avgas & Jet-A Into-Plane Systems
with Remote Off-Load and Dispensing

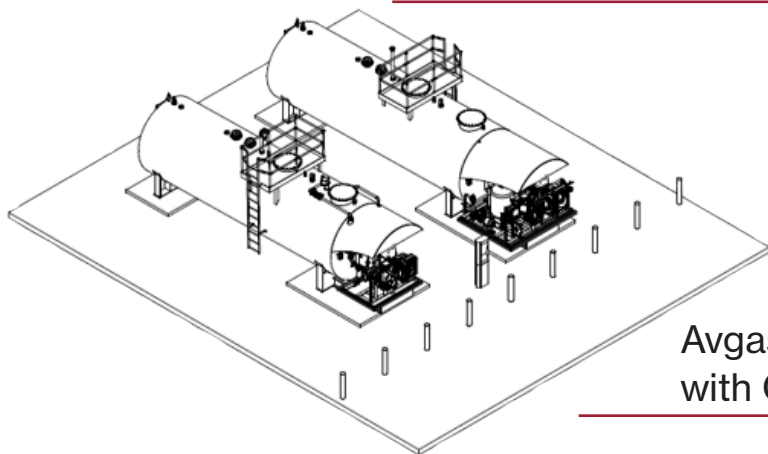

Avgas & Jet-A Systems
with Canopy Style Tank

Tanks range from 500 Gallons to 30,000 Gallons

All AVGAS Systems include the following:

TANK: Interior Stainless Steel or Epoxy Coated Carbon Steel, Overfill Valve, Clock Gauge with Alarm, Emergency Vent, Pressure Vacuum Vent, Interstitial Leak Detection Gauge, Fill Piping with Check Valve, Butterfly Valve & 3" Cam-Lock Adapter, Vapor Recovery Adapter, Fill-Rite Hand Sump Pump. **DISPENSING SYSTEM:** Electronic Pump & Motor, Deadman, Filtration, Calibrated Meters, Hoses, Nozzles, and Much More.

For your convenience and a superior design we include:

- Through-head piping to reduce piping and connections from tank top piping.
- Nearly all components are housed under protective canopy.
- Double wall tank systems include an integral secondary containment and eliminate the need for a dike.

Jet Fuel Storage & Pumping

Tanks: 500 to 30,000 Gallons

Pumping Systems: 50 GPM in-to-plane to 600 GPM bulk loading

Pumping Skids and Cabinets from 22 GPM to 1000 GPM

All Jet Systems include the following: TANK: Interior Stainless Steel or Epoxy Coated Carbon Steel, Floating Suction, Overfill Valve, Clock Gauge with Alarm, Emergency Vent, Pressure Vent, Interstitial Leak Detection Gauge, Fill Piping with Check Valve, Strainer and 4" Cam-Lock Adapter, Fill-Rite Hand Sump Pump. **DISPENSING SYSTEM:** Electronic Pump & Motor, Deadman, Filtration, Calibrated Meters, Hoses, Nozzles, and Much More.

Garsite uses all stainless-steel piping for pumping systems and offers Stainless Steel Primary Tank. This package provides:

- Clean and dry fuel.
- Reduced maintenance expenses.
- Durable and lasting equipment.

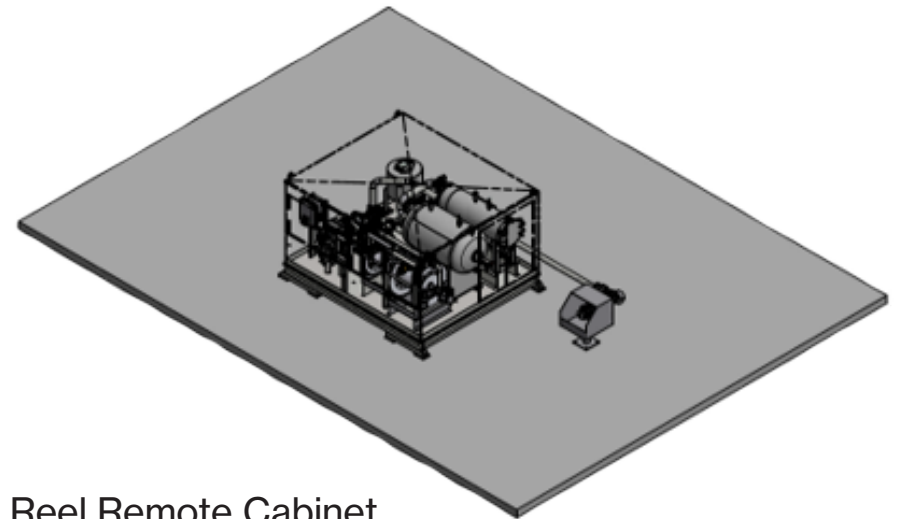

Dual Reel Remote Cabinet

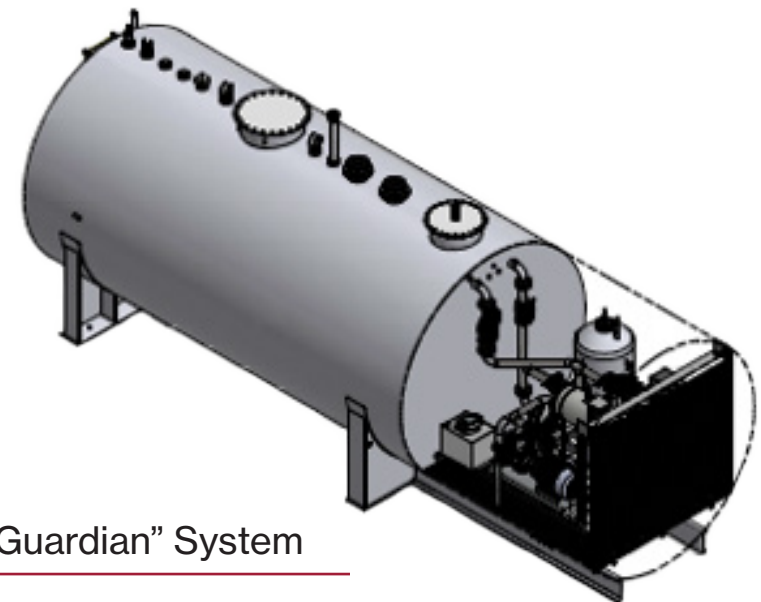

Garsite "Guardian" System

We are the experts

so you don't have to be!

First-Class

Safety and quality first! Garsite products are engineered for top performance. Our team knows the laws, regulations, and guidelines your equipment must meet for the highest safety standards.

Simple

Get it all with us! Our decades of industry experience allow us to streamline the process, making it simple for you! We don't cut corners, and you get a quality result.

Adaptable

Made to your specifications! Our team of engineers and sales support are here to create the equipment you need! Offering a wide variety of specifications to fit your use. Get the right equipment for the right job. Garsite will make it happen.

You get Garsite's highest quality, safety, flexibility, support and long-term investment value from our world-class engineering and over 65 years of fuel farm installation experience. From standard to custom design, call Garsite for your fuel storage and pumping requirements.



Garsite is your one-call, single-source supplier from design through installation and training. Our experts working for and with you to make fueling simple!



*Over 65 Years of Industry
Service and Innovation!*

GARSITE

**FUELING
MADE
SIMPLE**

539 South 10th Street Kansas City
Kansas 66105

info@garsite.com

913-342-5600

Garsite.com



Base specifications are accurate at the time of publication, and are subject to change without notice. Custom options are available; please consult your Garsite representative for additional information.

GAR 0004 10.15 - V1