

17K LITER JET REFUELER - JIG COMPLIANT

WWW.GARSITE.COM

GARSITE

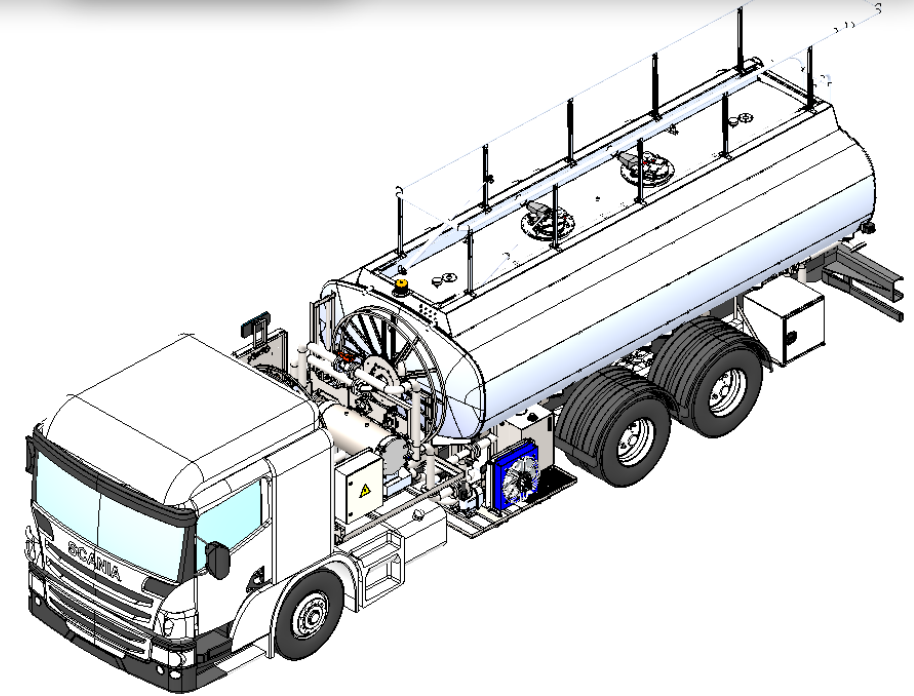
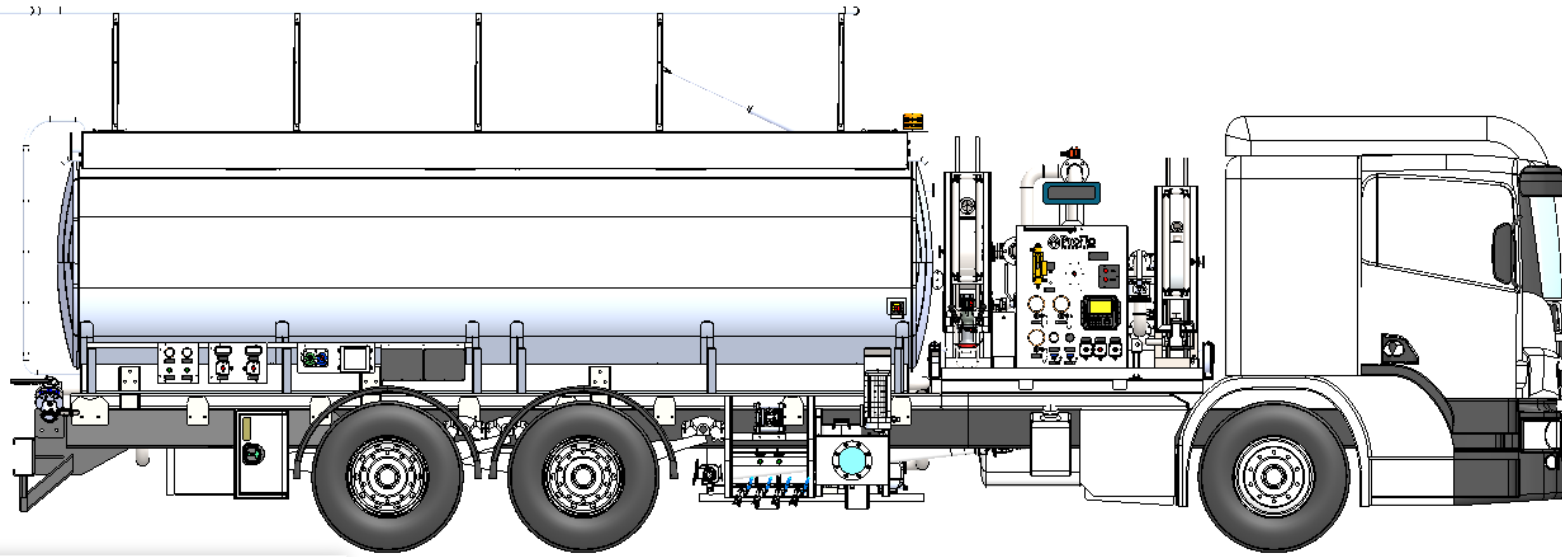

FEATURES

Chassis

- SCANIA L B6X2NB WB 4350mm Extend 400mm EURO 6
- Subframe Between Tank/Module and Chassis
- Rear Bumper w/ ADR Certificate
- 17,100 Liter Tank w/ 2 Compartments (8300 L/8300 L) w/ ADR Certificate
- Aluminum Tank - Sill Mounted and Painted One Color
- Rear Ladder and Pneumatic Collapsible Handrails
- (2) Pneumatic Vent and (2) Internal Valve Loading/Off-loading
- (2) Air Float-Primary High Level
- (2) Ultrasonic Sensor-Secondary High Level
- (2) Drains w/ Kamlok Adapter and Dust Cap

Fueling System – 1135 LPM

- (1) Single-Wrap Hose Reel Behind the Cab w/Hydraulic Rewind
- (1) 3' Venturi
- (1) ELAFLEX Fueling Hose 50mm x 15.25 M
- (1) Cla-Val Underwing Nozzle w/45 PSI HECV
- (1) Single-Wrap Hose Reel Inside Module w/Hydraulic Rewind
- (1) ELAFLEX Fueling Hose 38mm x 15.25 M

- (1) Gammon Overwing Nozzle
- (1) 300 GPM Meter and LCR IQ Register w/ Large Display
- Facet Latest Edition FWS w/Water Defense
- Hydraulically Driven Pump w/Bypass
- Inline Deadman Valve w/Electronic Controls and Timer System
- 4L Visual Sampler
- 75L Stainless Steel Product Recovery Tank
- Hydraulic Recovery Tank Pump Driven by Pneumatic

Also Included

- Stainless-Steel Piping
- Stainless-Steel Brackets
- Stainless-Steel Tubing for Sense and Drain Lines
- 24VDC Electric System ATEX Compliance
- PLC Control System
- (2) Electric Emergency Shutoff Switches
- (2) 20Lb Fire Extinguishers w/Brackets
- Logo Decals According to Local Regulations
- Operation and Maintenance Manual